



Raul Reyes
www.raulreyes3d.com
Youtube Rreyes3d leather
[instagram:@raulreyes3d](https://www.instagram.com/raulreyes3d)

1. PRINT THE PATTERN ON HEAVY CARD STOCK OR NORMAL PAPER AND GLUE IT ON SOMETHING THICKER (SET YOUR PRINTER TO A4 WITH NO MARGIN OR SELECT ACTUAL SIZE)
2. USE THE TEST PAGE TO VERIFY THE DIMENSIONS
3. CUT OUT THE PAPER PATTERN PIECES
4. TRACE THE PATTERN ONTO LEATHER AND CUT ALL THE PIECES REQUIRED
5. YOU CAN WATCH THE FOLLOWING VIDEO TUTORIAL TO SEE THE FULL PROCESS <https://www.youtube.com/channel/UC1ksyC2LQS8q0tV2TtGHqFg>

*YOU CAN ALSO USE OUR FREE 3D CONFIGURATOR TO TEST COLOR AND STYLE COMBINATIONS: <https://www.raulreyes3d.com/TW05A3D>

recommended leather:
2 to 4 Oz Leather (0.9 to 1.5mm)



7,17 inches
[8.2 cm]



Raul Reyes
www.raulreyes3d.com
Youtube Rreyes3d leather
[instagram:@raulreyes3d](https://www.instagram.com/raulreyes3d)

USE THIS PAGE TO TEST YOUR PRINTER

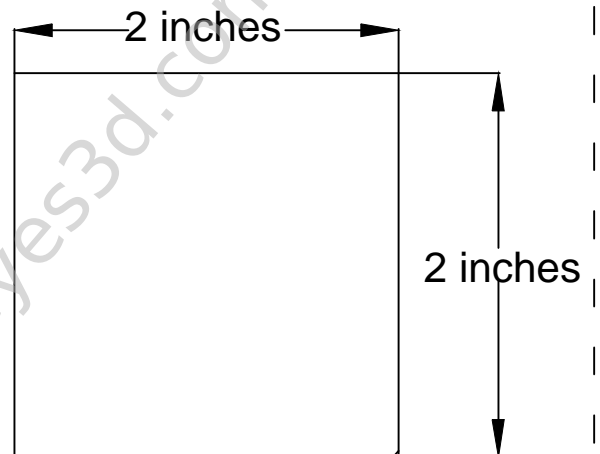
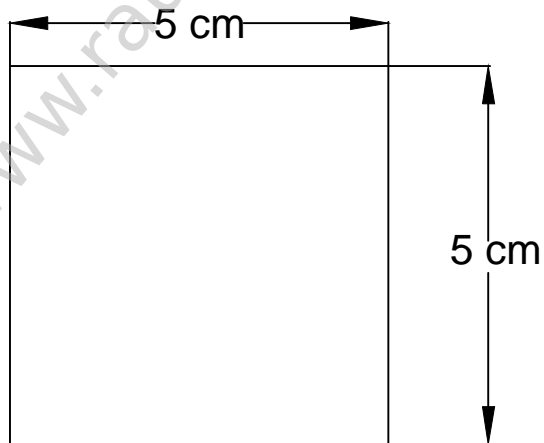

free pattern

www.raulreyes3d.com

1X MIDDLE PANEL

free pattern

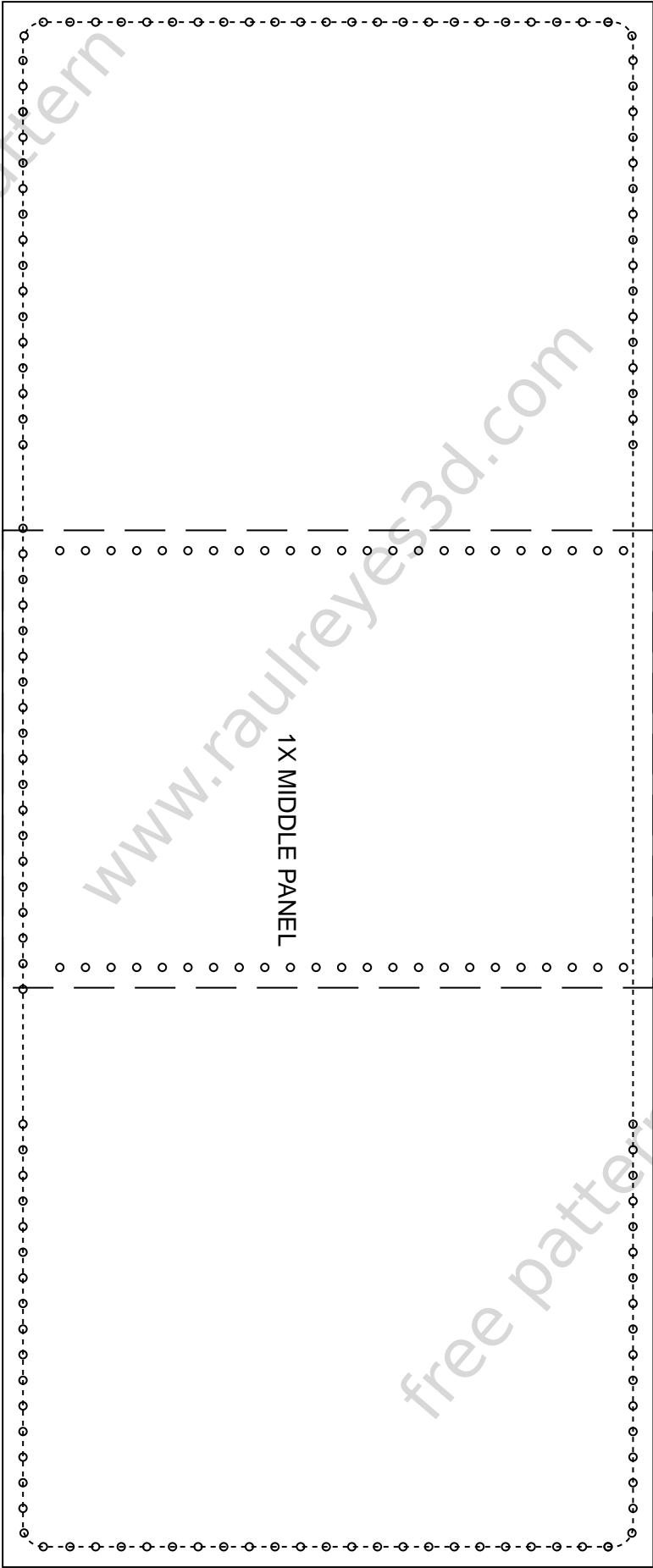

free pattern

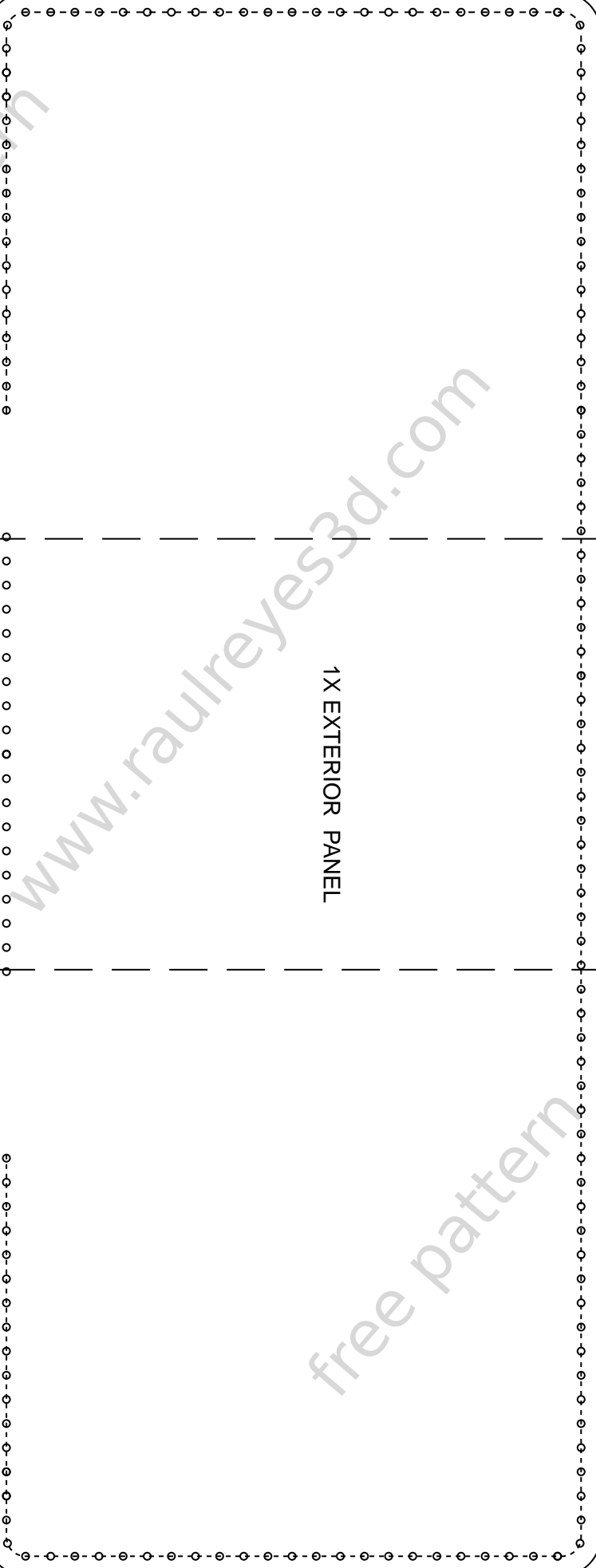

1X EXTERIOR PANEL

www.raulreyes3d.com

free pattern

CHOOSE A POCKET DESIGN

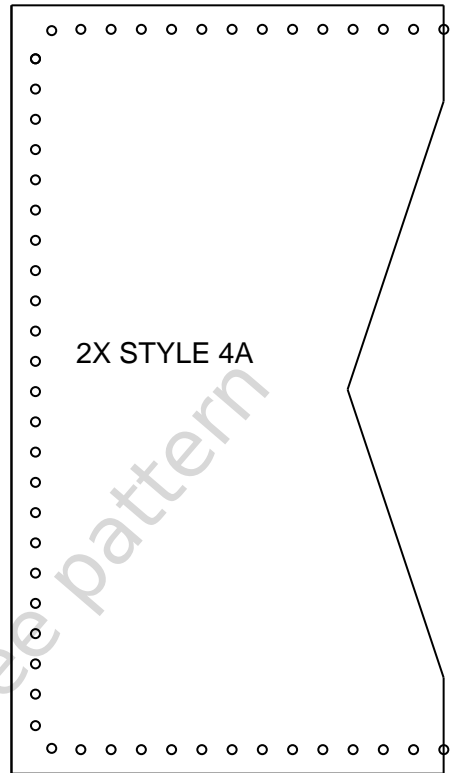
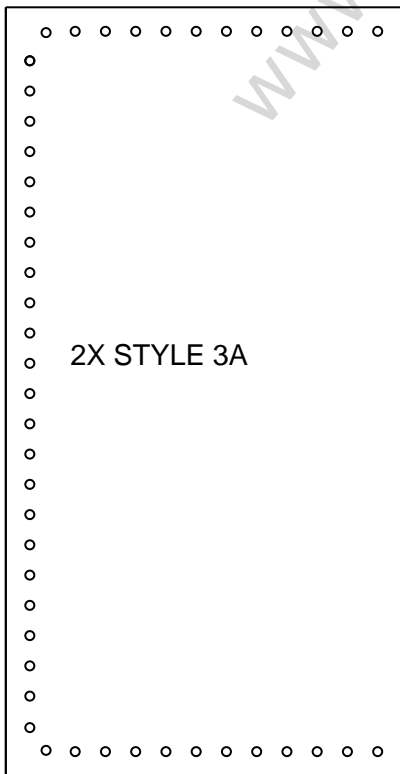
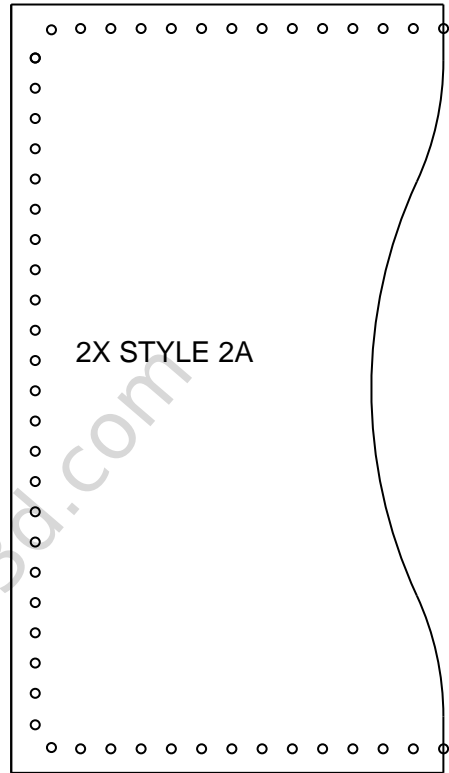
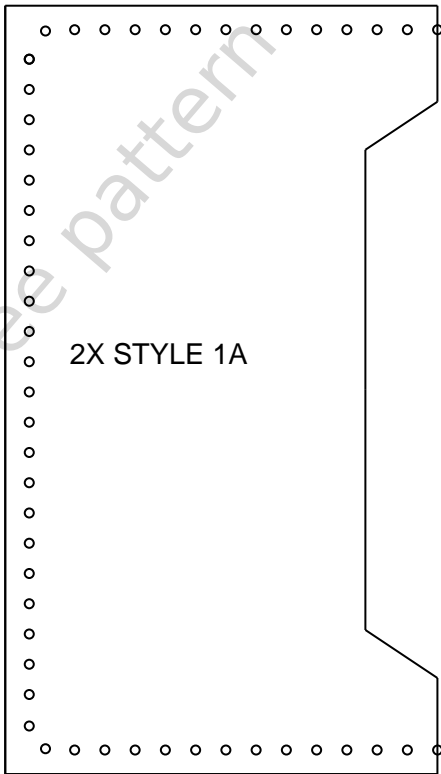

CHOOSE A POCKET DESIGN

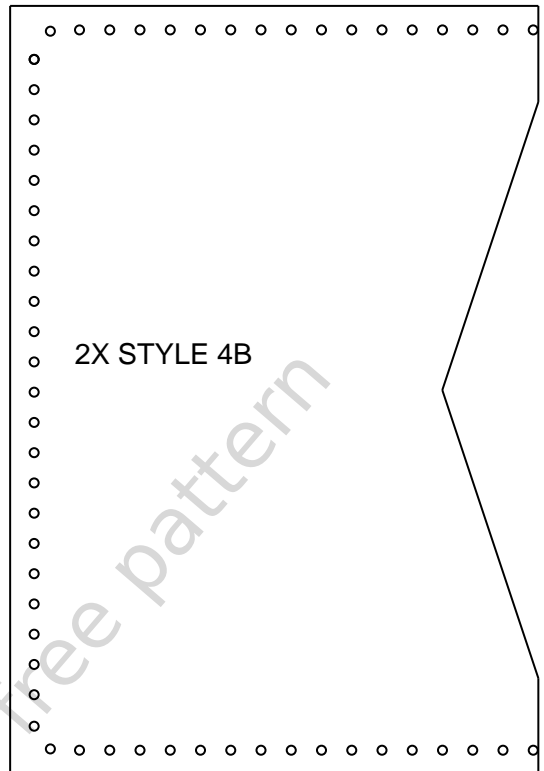
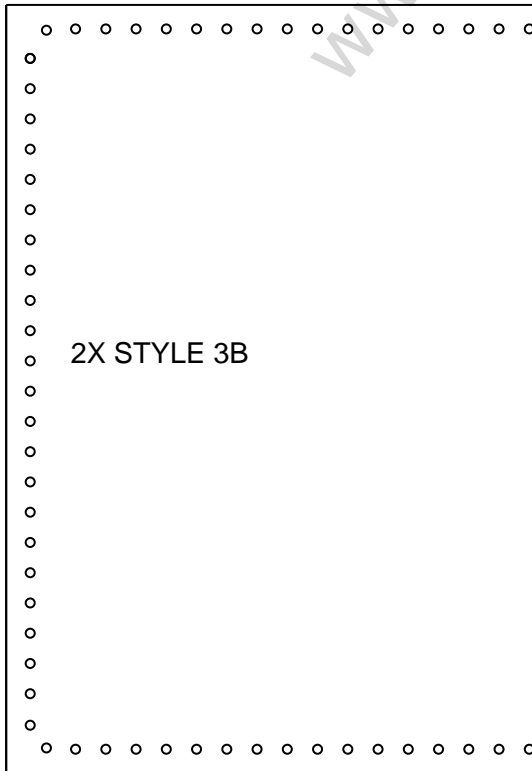
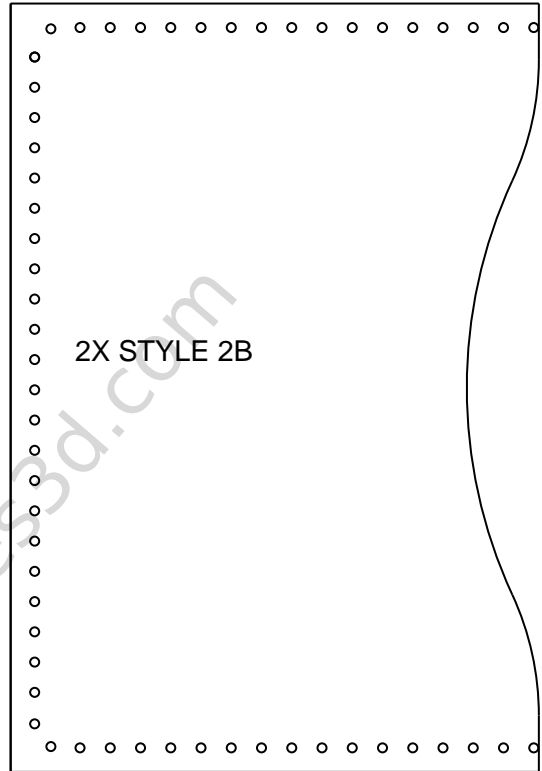
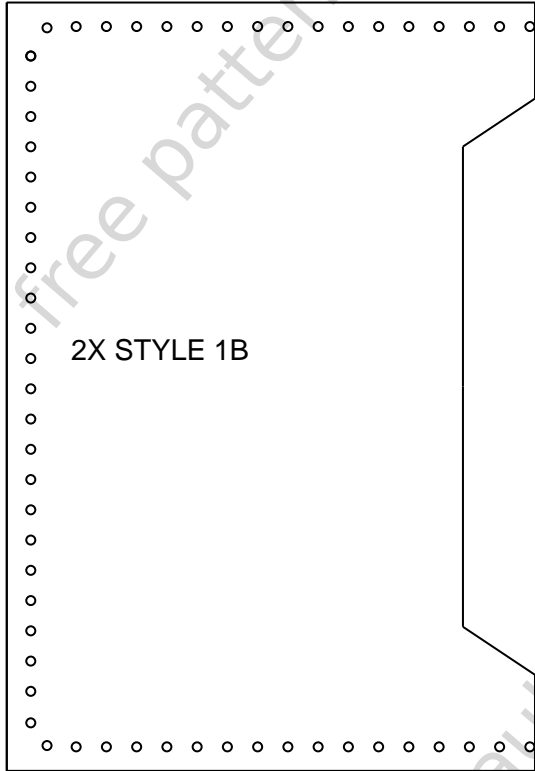

CHOOSE A MIDDLE PANEL DESIGN

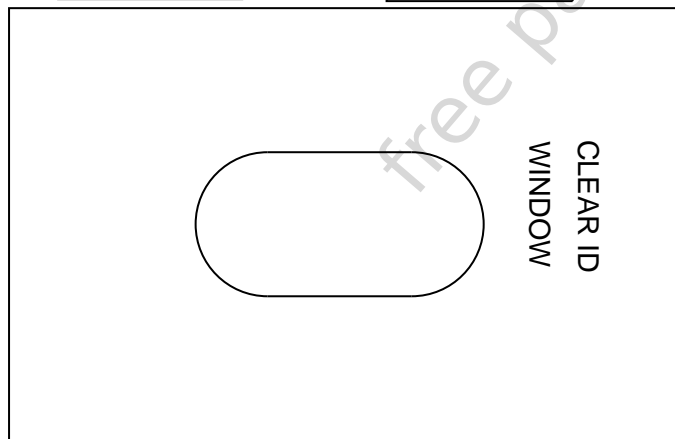
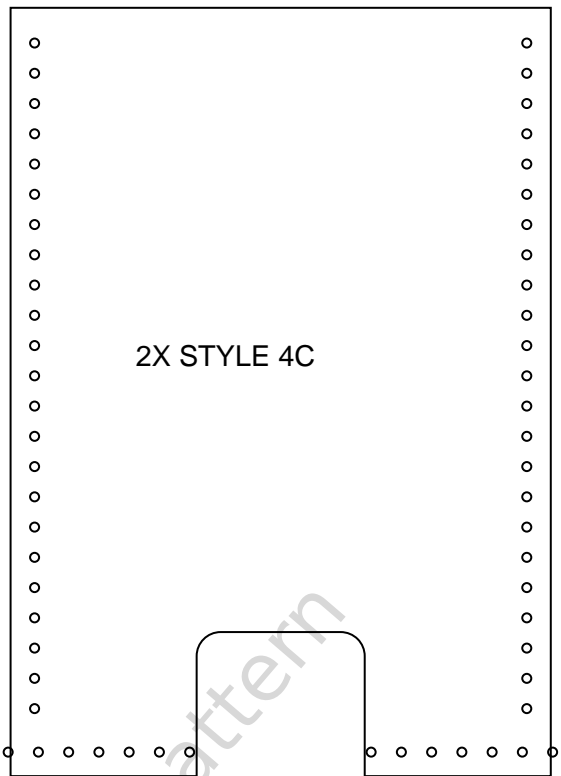
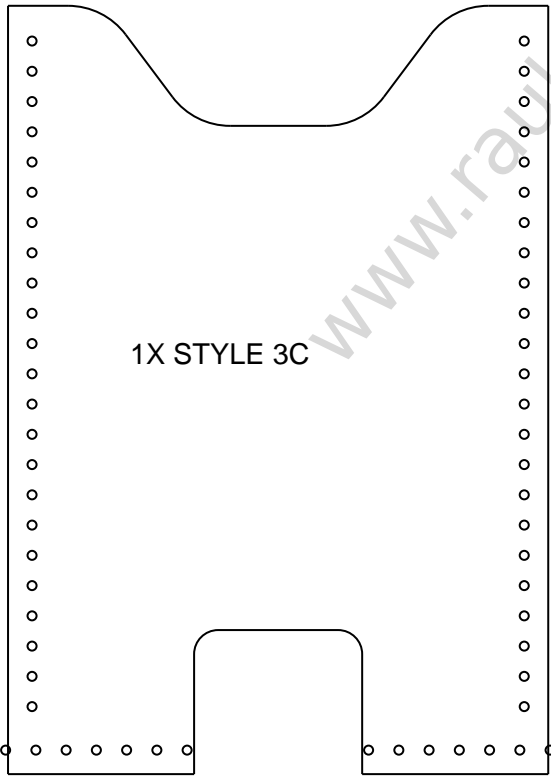
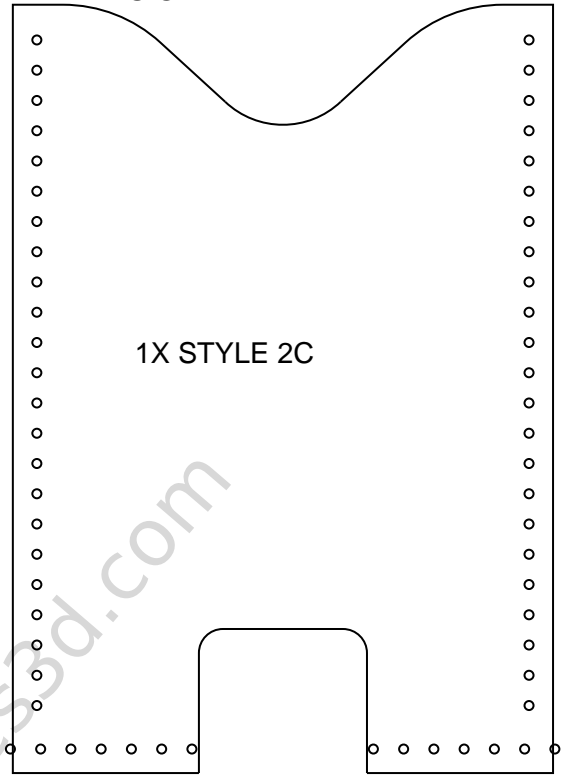
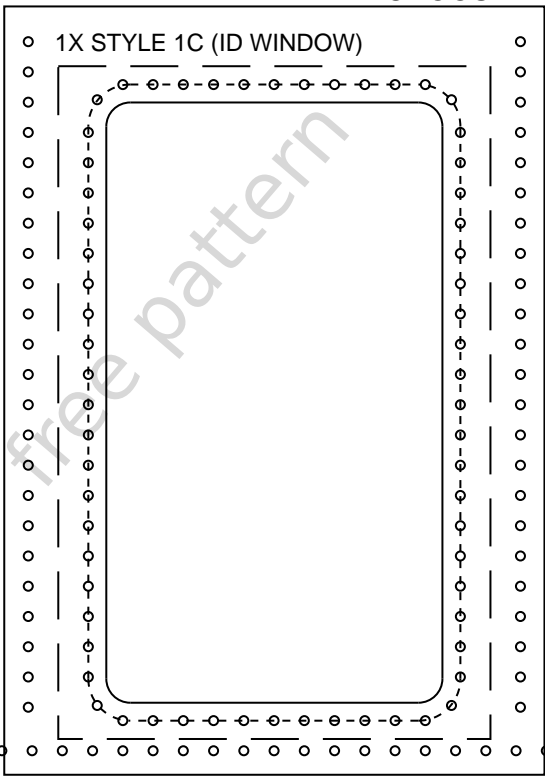

ASSEMBLY LAYOUT

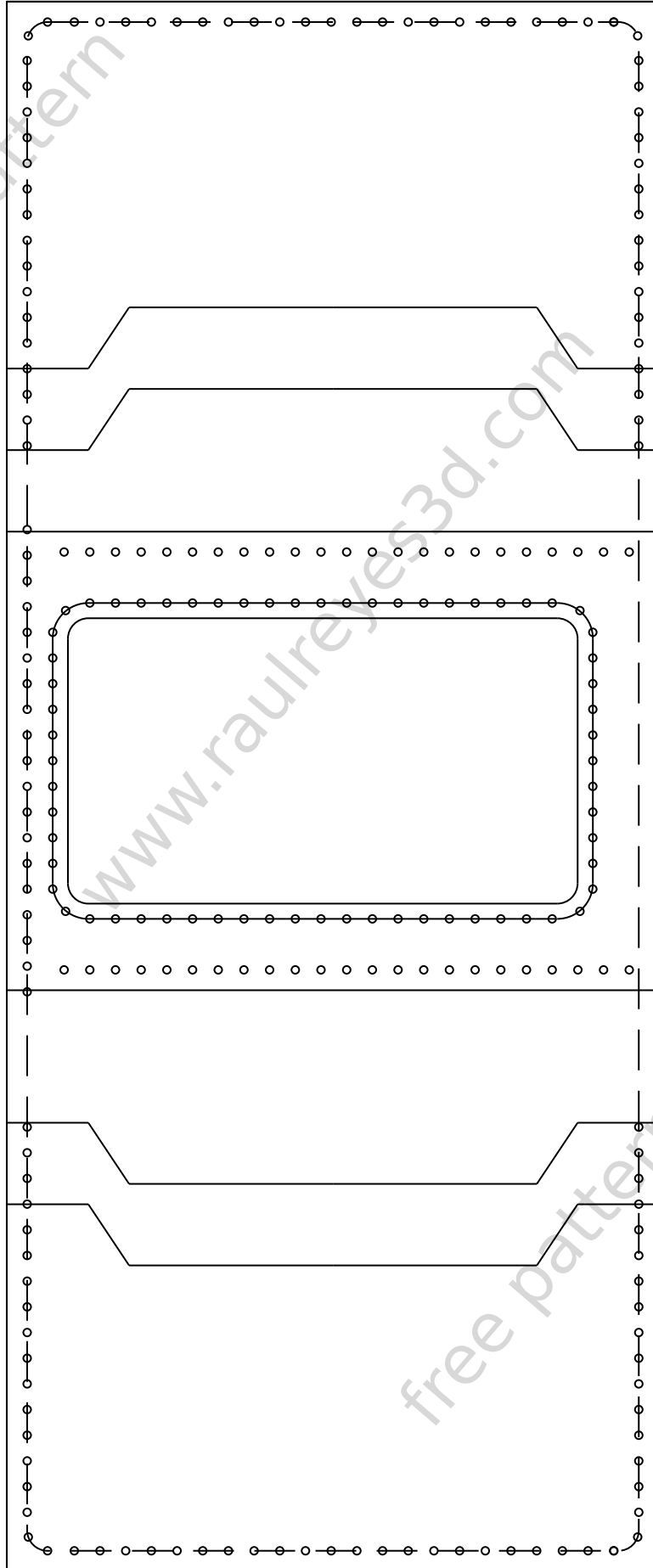

free pattern

www.raulreyes3d.com

free pattern